

**LYNX**<sup>®</sup>



WHAT'S NEW  
**MY26**

# QUICK RECAP OF 2025



## BRUTAL RE

Crossover with deep snow focus



## RAVE GLS

40th Anniversary Edition



## NEW LIMITED PACKAGE

and simplified lineup structure

# LYNX MY26 WHAT'S NEW



**COMMANDER** – THE MOST WANTED AND TRUSTED NOW ON RADIEN<sup>2</sup>



**SHREDDER** – MASTER THE SNOW WITH IMPROVED PRECISION



**CORE PACKAGE** – IN THE CORE OF LYNX RIDING EXPERIENCE



**BRUTAL, RAVE AND XTERRAIN** – MAJOR UPGRADES AND NEW PACKAGES

# LYNX MY26 WHAT'S NEW



**COMMANDER** – THE MOST WANTED AND TRUSTED NOW ON RADIEN<sup>2</sup>



SHREDDER – MASTER THE SNOW WITH IMPROVED PRECISION



CORE PACKAGE – IN THE CORE OF LYNX RIDING EXPERIENCE



BRUTAL, RAVE AND XTERRAIN – MAJOR UPGRADES AND NEW PACKAGES



# COMMANDER

## SPORT-UTILITY CROSSOVER



*Commander, the chief of snowfields, uniquely combines sporty trail characteristics with the power and capability of a wide-track snowmobile in deep snow. Europe's best-seller since 2009.*



## LED HEADLIGHTS

- Industry leading lighting power with 4800 lumens
- 2 high and 2 low beams
- 50% lower energy consumption



## 10.25" TOUCHSCREEN DISPLAY

- Built-in GPS and topographic maps
- Standard with RE, optional with Limited

# COMMANRER - 4-PISTON BRAKE



## 4-PISTON BRAKE

- More braking power for sporty riding with less effort
- Adjustable brake lever gives the final touch to perfect ergonomics
- Standard feature with RE package

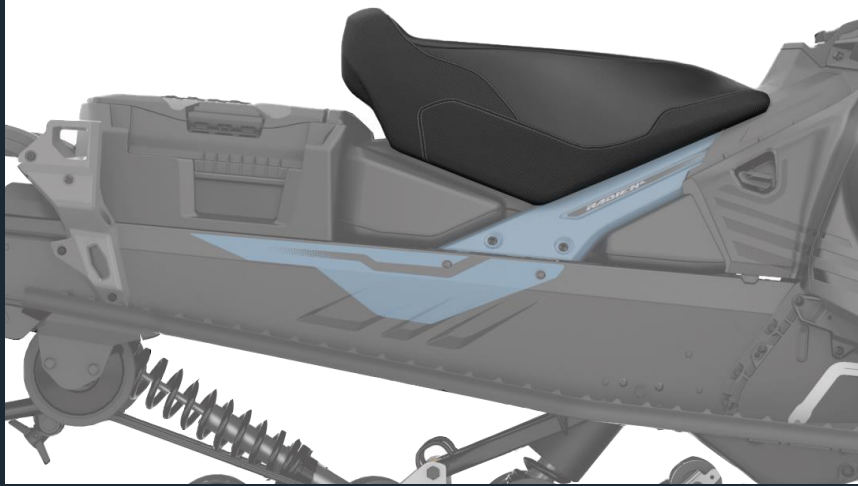

## NEW SEAT

- Narrower in the front and 10 mm lower at the back to support active riding
- New foam material for better comfort



## NEW HIGH WINDSHIELD

- Wide from the sides to keep your hands and shoulders warm
- Just the right height to ensure both great visibility and wind protection



# COMMANDER - STEERING



## UPDATED STEERING SYSTEM

- 6 mm shorter steering post arm and 4 mm less spindle trail for effortless steering
- Better directional stability for first-class riding experience

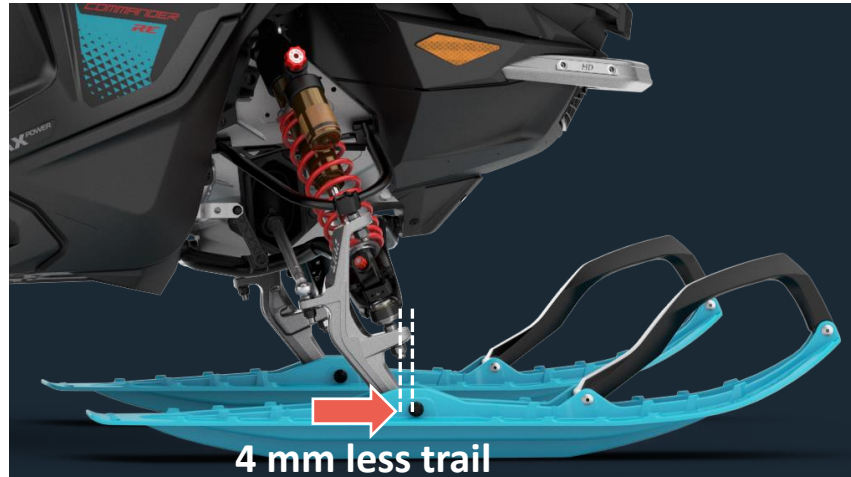

# COMMANDER - UPDATED FRONT SUSPENSION



## STRONGER, YET LIGHTER ARCHED A-ARMS

- High strength steel: 600 g lighter and +20 % stronger
- More responsive front suspension due to less unsprung weight

## NEW SWAY BAR SYSTEM

- Sway bar attached to the lower A-arm close to triple the stabilizing force
- Better stability when cornering



# COMMANDER - REDESIGNED SNOWFLAP AND RACK

## UNIQUE FLIPPABLE SNOWFLAP

- Better deep snow performance due to less drag from the snow
- Easier reversing in deep snow
- There when you need it – out of the way, when you don't

## UPDATED REAR RACK

- Industry leading cargo capacity of 61 kg, + 4.5 kg more than RADIEN-X
- Universal rack size to welcome more accessories



# COMMANDER - KEY NOVELTIES

10.25" touchscreen display

New seat

New rack

Flippable  
snowflap

Updated steering system

4-piston brake (RE only)

New windshield

Premium LED headlights

Radien<sup>2</sup> design

New arched A-arms and sway bar



# LYNX MY26 WHAT'S NEW



COMMANDER – THE MOST WANTED AND TRUSTED NOW ON RADIEN<sup>2</sup>



SHREDDER – MASTER THE SNOW WITH IMPROVED PRECISION



CORE PACKAGE – IN THE CORE OF LYNX RIDING EXPERIENCE



BRUTAL, RAVE AND XTERRAIN – MAJOR UPGRADES AND NEW PACKAGES

# SHREDDER

## DEEP SNOW

*Completely redesigned Shredder offers unmatched control in deep snow. The revamped Radien<sup>2</sup> chassis with a short and tapered tunnel, together with new rear and front suspensions, makes Shredder perfect machine for the untouched realms of deep snow.*

# SHREDDER - SUPER SHORT AND NARROW TUNNEL

-9 cm (3700 and 4100)

-7 cm (3900)



## NEW TUNNEL DESIGN

- Shorter, slimmer and narrower for better deep snow capability



# SHREDDER - SUPER SHORT AND NARROW TUNNEL

-9 cm (3700 and 4100)

-7 cm (3900)



## NEW TUNNEL DESIGN

- Shorter, slimmer and narrower for better deep snow capability
- New running boards for better snow evacuation and +20 mm more clearance



# SHREDDER - SUPER SHORT AND NARROW TUNNEL



## NEW TUNNEL DESIGN

- Shorter, slimmer and narrower for better deep snow capability
- New running boards for better snow evacuation and +20 mm more clearance
- New slim snow flap, rear lights and lightweight rear bumper as standard

# SHREDDER - SUPER SHORT AND NARROW TUNNEL

-11 cm (3700)

-25 cm (3900)

-36 cm (4100)

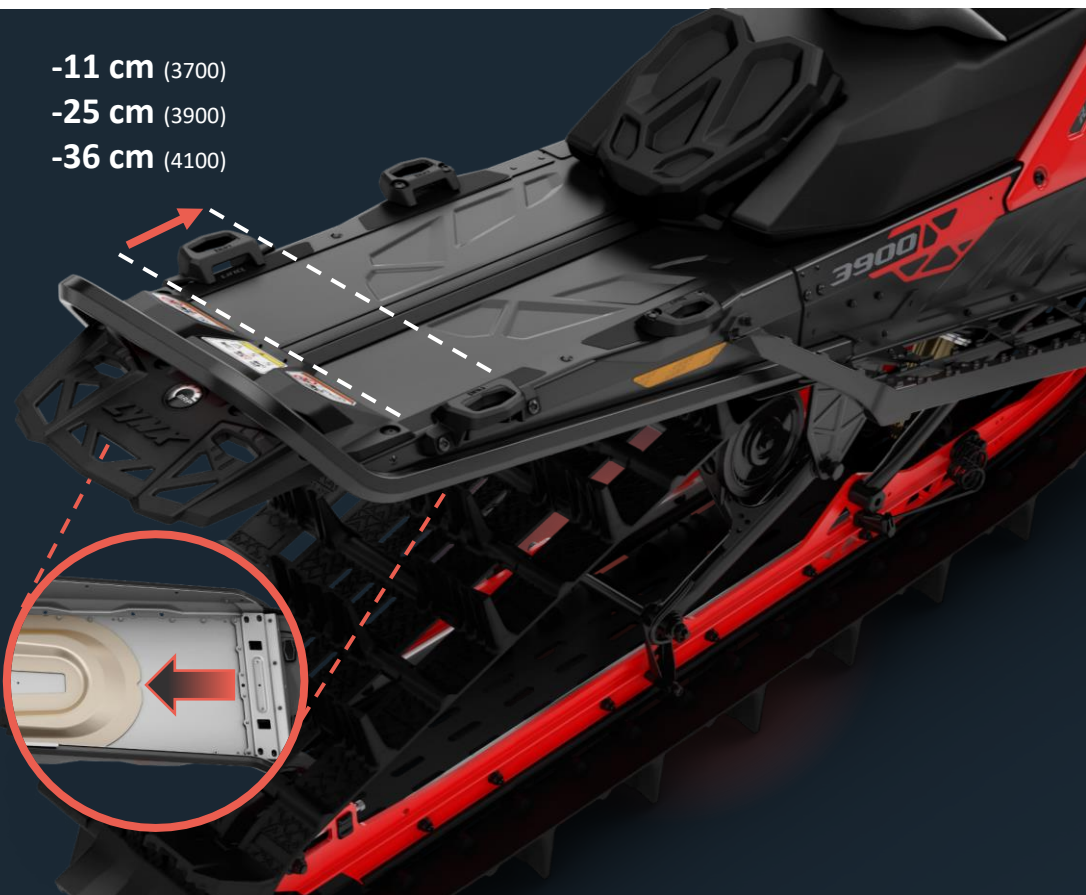

## NEW TUNNEL DESIGN

- Shorter, slimmer and narrower for better deep snow capability
- New running boards for better snow evacuation and +20 mm more clearance
- New slim snow flap, rear lights and lightweight rear bumper as standard
- Shorter tunnel heat exchanger for weight saving and less snow build-up

# SHREDDER - PPS<sup>3</sup>-DS REAR SUSPENSION

Long rail reinforcements  
(RE only)

Straight rear end of the rail  
for maximum grip and flotation

Repositioned rear links

Narrower slider shoes

New springs and shock  
calibrations

Smoother angle of attack  
to better climb on snow

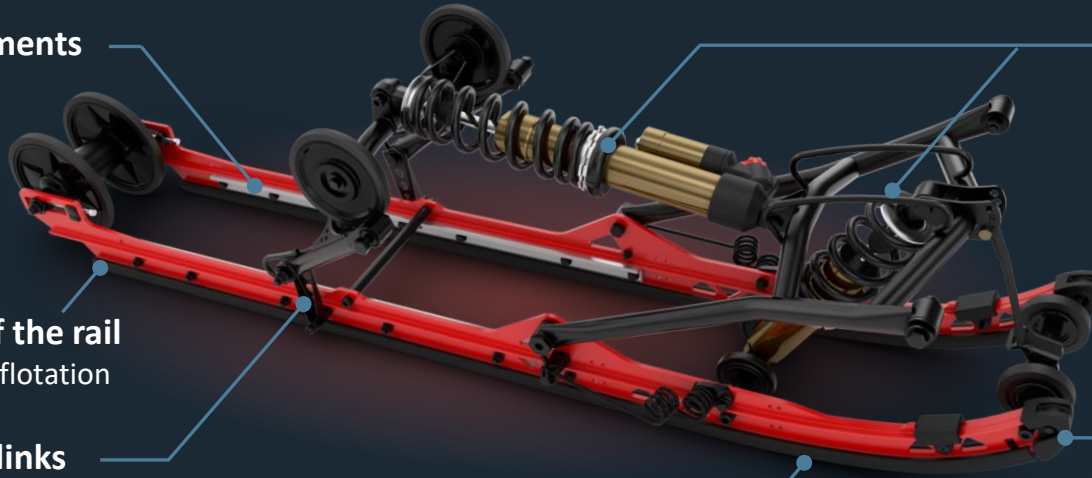

## UPDATED SUSPENSION GEOMETRY

PPS<sup>3</sup>-DS keeps the track more parallel to the chassis throughout the suspension travel resulting in better control in sidehilling

## OPTIMIZED TRACK TENSION

Track spins lighter resulting in not just less vibrations but also snappier throttle response and more power to the snow

# SHREDDER - PPS<sup>3</sup>-DS RAILS

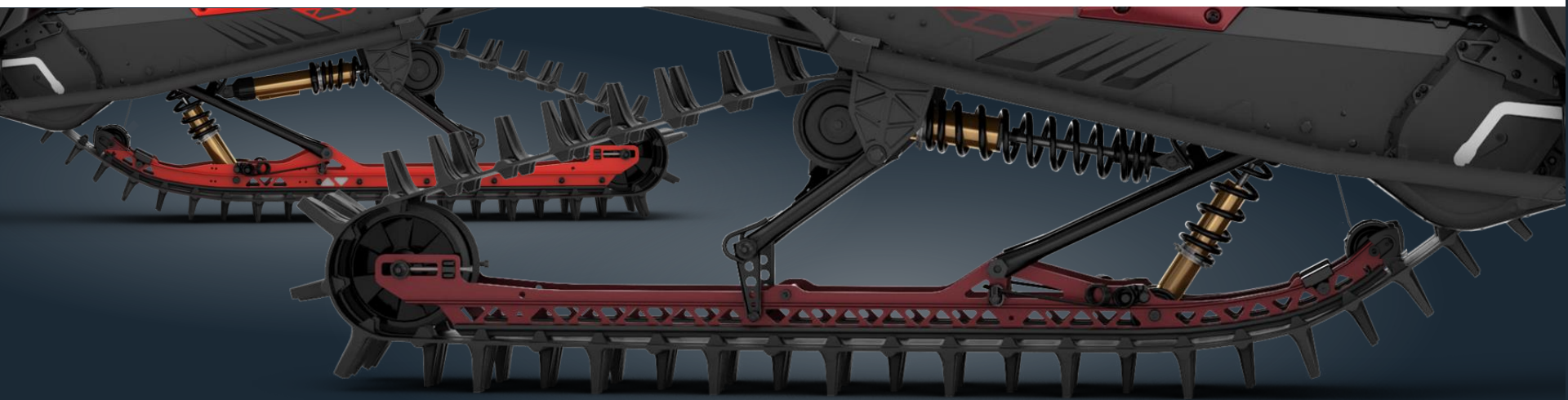

## LIGHTER VERSION IN SHREDDER DS

Light-weight rails with more openings to save weight and offer effortless technical riding in the steepest and deepest

## REINFORCED VERSION IN RE

Stronger rails with extra long rail reinforcements to hit big jumps and smooth landings with confidence



# LFS-DS FRONT SUSPENSION



## TWIN LINK STEERING

- Together with the new spindle, skis turn up to 40% more
- Designed for serious powder play – tighter maneuvers and easier countersteering and sidehilling

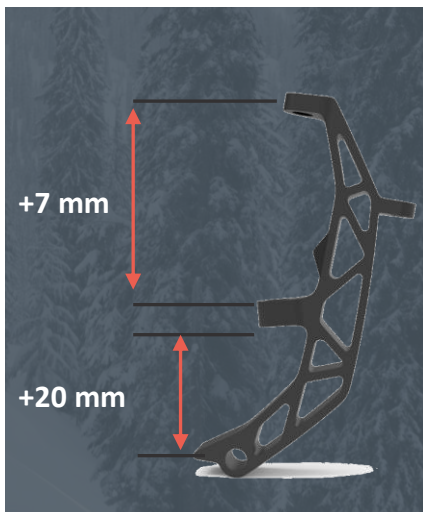

## NEW SPINDLE

- 20 mm more ground clearance – less drag in deep snow
- 100% optimized for deep snow riding

# SHREDDER - BLADE DSS SKIS

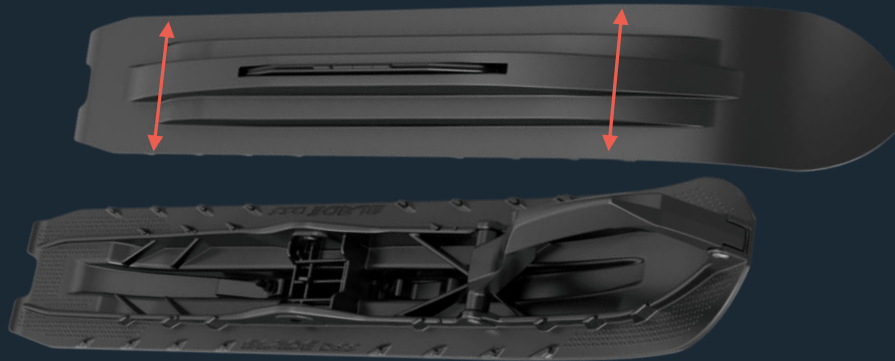

## BLADE DSS

- **10 mm narrower** – Easier to counter steer, easier to push into the snow
- **250 g weight saving** – Less unsprung weight, more precise suspension function
- **New, more balanced keel design** – Predictable steering in all snow conditions





# SHREDDER - IMPROVED ERGONOMICS

Ultra compact seat

Lower 90 mm riser

20 mm higher running boards



**ERGONOMICS OPTIMIZED  
FOR TECHNICAL RIDING**

- Higher running boards and lower handlebar improve control in steep slopes
- Easier hopovers due to lower seat and higher running boards

# SHREDDER - KEY NOVELTIES

Ultra compact seat

Up to **5 kg** lighter!

Short tapered tunnel

LFS-DS front suspension

Higher and more open running boards

PPS<sup>3</sup>-DS rear suspension

Blade DSS skis



# LYNX MY26 WHAT'S NEW



COMMANDER – THE MOST WANTED AND TRUSTED NOW ON RADIEN<sup>2</sup>



SHREDDER – MASTER THE SNOW WITH IMPROVED PRECISION



CORE PACKAGE – IN THE CORE OF LYNX RIDING EXPERIENCE



BRUTAL, RAVE AND XTERRAIN – MAJOR UPGRADES AND NEW PACKAGES

# CORE PACKAGE



*In the Core of **LYNX** riding experience. All you need for serious riding in the rough Nordic conditions at a wallet-friendly price tag.*



# CORE - HIGH-PERFORMANCE SUSPENSION

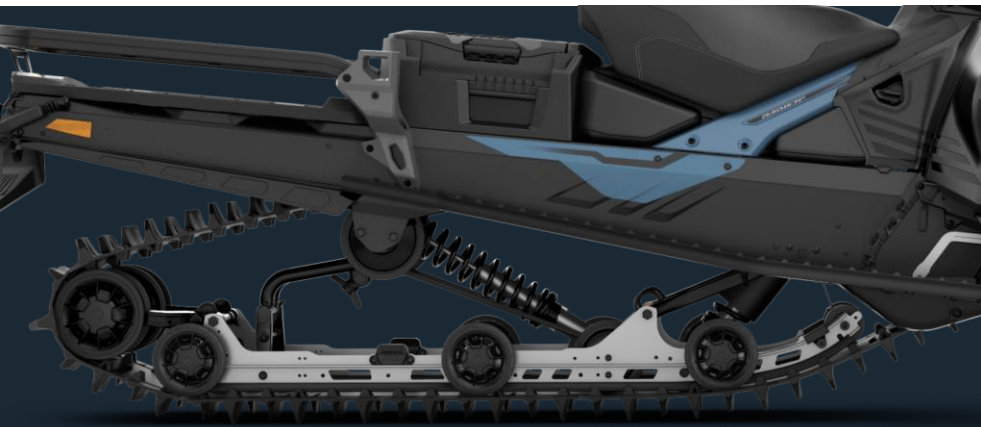

## HIGH-PERFORMANCE SUSPENSION SYSTEMS

- EasyRide+, PPS<sup>3</sup>, PPS<sup>2</sup>-DS+
- Robust and durable structure

## KYB SHOCKS WITH COILOVER SPRINGS

- High quality shocks for longevity
- Preload easily adjustable

# CORE - ROTAX ENGINES

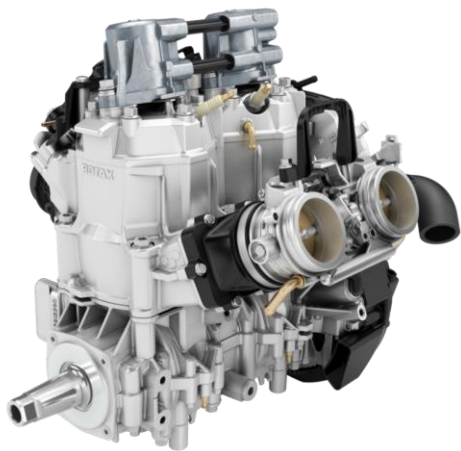

## E-TEC / EFI 2-STROKE ENGINES

- Reliable and fuel-efficient
- Responsive and light-weight
- Rewind back-up starter standard
- New more refined 600 EFI with Radien<sup>2</sup>
  - New electronic oil pump for more precise oil injection and reduced oil consumption
  - Four engine mounts for less vibrations

## ACE 4-STROKE ENGINES

- Reliable and fuel-efficient
- Great torque for towing
- Low vibration and noise levels
- Low cost of ownership

All Rotax engines are known for class-leading engine technology, reliability and fuel efficiency



# CORE - RADIIEN<sup>2</sup>



## LED HEADLIGHTS\*

- Doubles the lighting power
- Bright white light for modern look

\* Excluding 59 Ranger Core



## ERGONOMICS FOR ACTIVE RIDING

- Easy to control, easy to move around
- Less rider's fatigue

# CORE - LINQ ACCESSORY SYSTEM

**LINQ**  
SYSTEM®



## LINQ SYSTEM

- The widest accessory selection on the market
- Easy and to quick to use
- Accessorize your Lynx to match to your needs

# CORE - KEY FEATURES

Ergonomics for active riding

LinQ accessory system

Robust high-performance suspension

KYB shocks



Radien<sup>2</sup> design with LED headlights  
(excl. 59 Ranger)

Rotax engines

- reliable and fuel efficient
- manual backup starter standard (2-str)



ADVENTURE



XTERRAIN



COMMANDER



SHREDDER



49 RANGER



59 RANGER

# LYNX MY26 WHAT'S NEW



COMMANDER – THE MOST WANTED AND TRUSTED NOW ON RADIEN<sup>2</sup>



SHREDDER – MASTER THE SNOW WITH IMPROVED PRECISION



CORE PACKAGE – IN THE CORE OF LYNX RIDING EXPERIENCE



BRUTAL, RAVE AND XTERRAIN – MAJOR UPGRADES AND NEW PACKAGES



BRUTAL



OFF-TRAIL  
CROSSOVER



*When a little too much is just enough! Brutally deep snow capable crossover sled that knows no limits.*

*Its powerful engine, high-performance suspension and track with superior grip and flotation makes it an unstoppable beast that can master any riding condition.*



# BRUTAL RE 20"

## NEW RUNNING BOARDS FOR BETTER OFF-TRAIL CAPABILITY AND HANDLING

- 36 mm narrower on each side for more agility in deep snow
- Deep snow inspired profile for better grip
- Larger openings for better snow evacuation



# BRUTAL RE 20" - KEY NOVELTIES

10.25" touchscreen display

4-piston brake

Radien<sup>2</sup> design

Premium LED headlights

Four engine mounts  
(2-stroke)

Flippable snowflap

Deep snow style running boards

Updated steering system



RAVE

TRAIL



*With its pure racing pedigree, Rave is synonymous with speed and performance, excelling in demanding and wide-ranging trail conditions like no other. The fiercer the trail, the greater the pleasure.*

# RAVE RE - LFS-R FRONT SUSPENSION

## BETTER CORNERING STABILITY

- More tilted shock angle, repositioned sway bar linkage and new ski leg lead to 20% less chassis roll for flatter cornering

## HIGHER GROUND CLEARANCE

- Taller ski leg increases clearance allowing you to hit the snowy bumps with confidence

## MORE SUSPENSION TRAVEL

- Rail through moguls like they didn't even exist

+26 mm

+11 mm

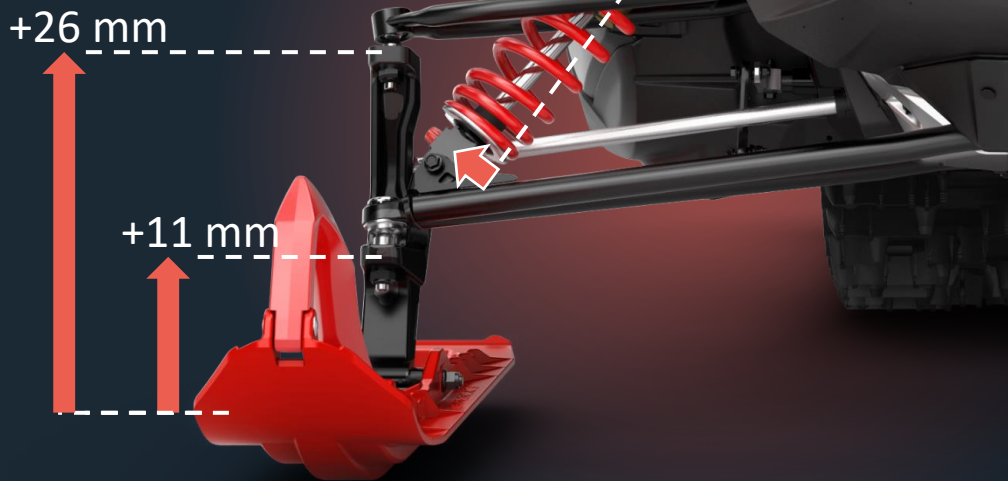



# RAVE RE - KEY NOVELTIES



**NEW Black Edition**  
(850 E-TEC Turbo R only)



Engine options:  
600R E-TEC  
850 E-TEC  
**NEW 850 E-TEC Turbo R**

**LFS-R front suspension**



**XTERRAIN**

**TRAIL  
CROSSOVER**



*Originally developed for high-stakes endurance races like the legendary Cain's Quest.*

*The combination of high-end trail capacity and off-trail capabilities make Xterrain the perfect sled for the rider who refuses to be defined by terrain.*

# XTERRAIN - NEW LIMITED PACKAGE



**Passenger kit**  
(optional with 900 ACE Turbo)

**10.25" touchscreen display** (optional)

**Heated seat**

**Premium coloration**

**51 mm Powdermax track**

**Premium KYB Plus shocks**

Skis: KYB 36 Plus R

Center: KYB 36 Plus Kashima

Rear: KYB 46 Plus Kashima

**Engine options:**  
600R E-TEC  
900 ACE Turbo



**Serious crossover performance combined with comfort and premium looks**

# MY26 CONNECTIVITY | PRODUCT NEWS

1

## 10.25" DISPLAY



Embedded Maps Improvements  
Simplified Center Gauge Management

2

## BRP GO!



Improved Group Riding  
Improved Route Creation  
Route Modification On The Go

3

## VIBE COMM SYSTEM



Enhanced Headset Management  
Group Mesh

# MY26 CONNECTIVITY | PRODUCT NEWS

## BRP GO! APP

- **Improved route creation**
  - Decide between autorouting (on trail) or manual routing (off-trail)
  - Easily add precise waypoint
- **Route modification on the go**
  - Add new stop during a ride
- **Improved group riding experience**
  - Create and manage groups
  - Easily share position with group members

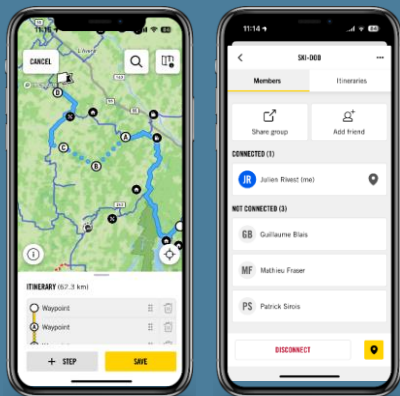

## VIBE COMMUNICATION SYSTEM

- **Enhanced headset management**
  - Sound settings (equalizer, smart volume...)
  - Microphone (mic sensitivity...)
  - Mesh Intercom (channel management...)
  - Firmware updates
- **Private group communication**
  - Available with Vibe devices only

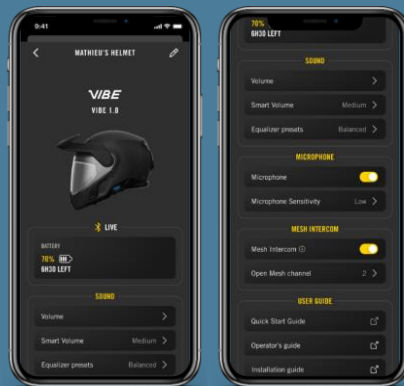

# LYNX MY26 WHAT'S NEW



**COMMANDER** – THE MOST WANTED AND TRUSTED NOW ON RADIEN<sup>2</sup>



**SHREDDER** – MASTER THE SNOW WITH IMPROVED PRECISION



**CORE PACKAGE** – IN THE CORE OF LYNX RIDING EXPERIENCE



**BRUTAL, RAVE AND XTERRAIN** – MAJOR UPGRADES AND NEW PACKAGES



# WHAT'S NEW 2026 SUMMARY

---



# RAVE

OFF-TRAIL  
TRAIL  
TOWING



Ultimate rough trail performance since 1990



## RAVE RE

- 600R E-TEC / 850 E-TEC / **850 E-TEC TURBO R**
- 10.25" display option (600R only, standard with other engines)
- Spring options:
  - **Black Edition** (Turbo only)



## RAVE RE with Enduro package

- 600R E-TEC

## WHAT'S NEW

LFS-R front suspension

Track: 38 mm Ice-Ripper XT  
(excluding 600R EU model with 41 mm Cobra)

Starter: Electric with 600R E-TEC and 850 E-TEC,  
SHOT with 850 E-TEC Turbo R

# ADVENTURE

OFF-TRAIL  
TRAIL  
TOWING



For trail adventures to remember

NEW



## ADVENTURE CORE

- 600 ACE

NEW



## ADVENTURE LX

- 600 ACE



## ADVENTURE LIMITED

- 900 ACE
- Passenger kit option

## WHAT'S NEW

Radien<sup>2</sup> design

3500 x 32 mm (137"x1.25") Ripsaw track

3500 x 32 mm (137"x1.25") Ripsaw track

# ADVENTURE

OFF-TRAIL  
TRAIL  
TOWING



For trail adventures to remember



## ADVENTURE ELECTRIC

- Rotax E-POWER
- 3100 / 3500

WHAT'S NEW

# XTERRAIN

OFF-TRAIL  
TRAIL  
TOWING



Extreme crossover sled with superior trail performance for long-distance adventures

NEW



## XTERRAIN CORE

- 600 EFI / 600 ACE

NEW



## XTERRAIN LIMITED

- 600R E-TEC / 900 ACE Turbo
- 10.25" display option
- Passenger kit option (4-str. only)



## XTERRAIN RE

- 900 ACE Turbo R / 850 E-TEC / 850 E-TEC Turbo R
- Spring options:
  - 41mm Ice Cobra studded track (4-str. only)
  - Black Edition (Turbos only)

## WHAT'S NEW

Radien <sup>2</sup> design	Heated seat
600 EFI: 381 mm (15") track width 600 ACE: 41mm (1.6") Cobra track	381 mm (15") track width
Premium coloration	10.25" touchscreen display standard
KYB 36/36/46 Plus shocks	4-piston brake with adjustable lever



# BRUTAL

OFF-TRAIL  
TRAIL  
TOWING



Brutally deep-snow capable crossover for the journeys to the unknown



## BRUTAL RE (narrow)

- 850 E-TEC (Not available in NA) / 900 ACE Turbo R
- 381 x 3900 x 64 mm (15 x 154 x 2.5") track
- Spring options:
  - Black Edition (Turbo only)

NEW



## BRUTAL RE (wide)

- 850 E-TEC / 900 ACE Turbo R
- 500 x 3900 x 60 mm (20 x 154 x 2.4") track
- Spring options:
  - Black Edition (Turbo only)

## WHAT'S NEW

4-piston brake with adjustable lever

10.25" touchscreen display standard

381 mm (15") track width

Radien<sup>2</sup> design

Flippable snow flap  
Deep snow style running boards  
Updated steering mechanism

# SHREDDER

OFF-TRAIL  
TRAIL  
TOWING



For the steepest slopes and the dopest snow



## SHREDDER CORE

- 3700 / 3900
- 600R E-TEC



## SHREDDER DS

- 3900 / 4100 (Spring only)
- 850 E-TEC / 850 E-TEC Turbo R
- Spring options:
  - 4100 track length (Turbo only)
  - Black edition (Turbo only)



## SHREDDER RE

- 3700 / 3900
- 600R E-TEC (3700 only) / 850 E-TEC / 850 E-TEC Turbo R
- Spring options:
  - Electric starter (3700 850 E-TEC with 10.25" only)
  - Black edition (Turbo only)

## WHAT'S NEW

Electric starter standard

10.25" display standard with 850 E-TEC Turbo R (optional with 850 E-TEC)

Short tapered tunnel with narrow snowflap and rear bumper

Higher and more open running boards

PPS<sup>3</sup>-DS rear suspension

LFS-DS front suspension with twin link steering system

Blade DSS skis

Ultra compact seat

90 mm riser

# COMMANDER

OFF-TRAIL  
TRAIL  
TOWING



The most versatile snowmobile that masters both on and off-trail and pulls the heaviest of loads.

NEW



## COMMANDER CORE

- 600R E-TEC / 900 ACE / 900 ACE Turbo

NEW



## COMMANDER LIMITED

- 900 ACE / 900 ACE Turbo
- Passenger kit option
- Spring options:
  - 38 mm Ice Crosscut studded track

NEW



## COMMANDER RE

- 900 ACE Turbo R

## WHAT'S NEW

Radien<sup>2</sup> design

Flippable snow flap

Lighter and more durable arched A-arms with new sway bar linkage

Updated steering mechanism

New rear rack to welcome more accessories

10.25" touchscreen option

10.25" touchscreen standard

4-piston brake with adjustable lever

# 49 RANGER

OFF-TRAIL  
TRAIL  
TOWING



Effortlessly agile light utility for the uncharted territories

NEW



## 49 RANGER CORE

- 600 EFI / 600 ACE



## 49 RANGER PRO

- 600R E-TEC / 850 E-TEC

### WHAT'S NEW

Radien<sup>2</sup> design

38 mm Charger track

Lighter and more durable arched A-arms with new sway bar linkage

# 59 RANGER

OFF-TRAIL  
TRAIL  
TOWING



A modern-day work horse to get the job done



## 59 RANGER CORE

- 600 EFI / 600 ACE



## 59 RANGER PRO

- 600 ACE



## 59 RANGER ALPINE

- 900 ACE

## WHAT'S NEW

-

Mirrors



# 69 RANGER

OFF-TRAIL  
TRAIL  
TOWING



Heavy hauler for the most challenging work tasks



## 69 RANGER PRO

- 900 ACE / 900 ACE Turbo



## 69 RANGER ALPINE

- 900 ACE Turbo (with intercooler)

WHAT'S NEW

SEE YOU ON SNOW!

**LYNX**<sup>®</sup>

